

TV-13142/TV-13142W STANDARD CIRCUIT DIAGRAM

■ NOTE ON USING CIRCUIT DIAGRAMS

1.SAFETY

The Components identified by the symbol \triangle are critical for safety. For continued safety, replace safety critical components only with manufacturer's recommended parts.

2.INDICATION OF PARTS SYMBOL [EXAMPLE]

●In the PC board :R1209→R209

3.NOTE FOR REPAIRING SERVICE

This model's power circuit is partly different in the GND.

Please, care must be taken for the following points.

(1)Do not touch the LIVE side GND or the LIVE side GND and the ISOLATED(NEUTRAL) side GND simultaneously. If the above caution is not respected, an electric shock may be caused. Therefore, make sure that the power cord is surely removed from the receptacle when, for example, the chassis is pulled out.

(2)Do not short between the LIVE side GND and ISOLATED(NEUTRAL) side GND or never measure with a measuring apparatus (oscilloscope, etc.) the LIVE side GND and ISOLATED(NEUTRAL) side GND at the same time. If the above precaution is not respected , a fuse or any parts will be broken.

◇ Since the circuit diagram is a standard one, the circuit and circuit constants may be subject to change for improvement without any notice.

CONTENTS

SEMICONDUCTOR BASE CONNECTIONS	2
BLOCK DIAGRAMS	3
<i>TV BLOCK DIAGRAM</i>	
<i>Y/C/AUDIO/CCD/HEAD AMP/IN/OUT BLOCK DIAGRAM</i>	
<i>MICON/POWER/OPERATION/DECK BLOCK DIAGRAM</i>	
CONNECTION DIAGRAM	9
CIRCUIT DIAGRAMS	11
<i>SYSCON PCB IN/OUT SCHEMATIC DIAGRAM</i>	
<i>SYSCON PCB Y/C/AUDIO/CCD/HEAD AMP SCHEMATIC DIAGRAM</i>	
<i>SYSCON PCB MICON SCHEMATIC DIAGRAM</i>	
<i>SYSCON PCB CHROMA/IF SCHEMATIC DIAGRAM</i>	
<i>SYSCON PCB SOUND AMP SCHEMATIC DIAGRAM</i>	
<i>SYSCON PCB POWER SCHEMATIC DIAGRAM</i>	
<i>SYSCON PCB DEFLECTION SCHEMATIC DIAGRAM</i>	
<i>CRT PCB SCHEMATIC DIAGRAM</i>	
<i>OPERATION PCB SCHEMATIC DIAGRAM</i>	
<i>DECK PCB SCHEMATIC DIAGRAM</i>	
PATTERN DIAGRAMS	31
<i>OPERATION PCB PATTERN</i>	
<i>DECK PCB PATTERN</i>	
<i>SYSCON PCB PATTERN</i>	
WAVEFORMS	37

SEMICONDUCTOR BASE CONNECTIONS

DIODE

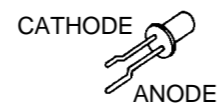

1SS133T-77
HZ11B3L TD
HZ27-1L TD
MTZJ33B T-77
MTZJ5.6B T-77
MTZJ6.8B T-77
MTZJ8.2AT-77
SB10-03A3

11E1-EIC
11EQS04N-TA1B2
11ES1-E1C

15DF6
RMPG06J-G3
RU2AM V1
SB290S

SID1050CM

SLZ-936C-07-S-T1

GBL06L-6177

IC

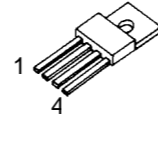
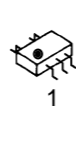
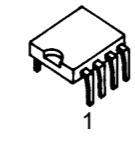
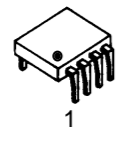
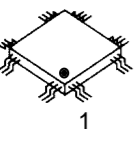
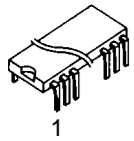

LB11880

LA71201M-MPB
M61206FP

S-24C04BDP-LA

AN7511

R3111N311A/C-TR

KIA78R05PI

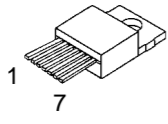
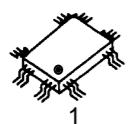
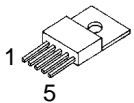

STR-G6623

OEC7059A

AN5522

TRANSISTOR

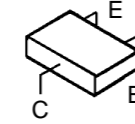
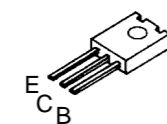
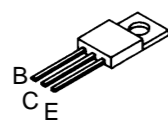
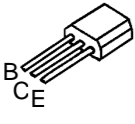
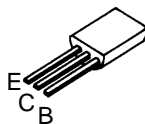

2SA1015Y(TPE2)
2SA1624-AA
2SC2120Y(TPE2)
2SC2271(D,E)-AE
2SD400E

KTA1281_Y
KTC3198-AT(Y,GR)
KTC3203_Y-AT

2SD2627LS-CBC11

2SC4217(D,E)-RAC

2SA1037AKT146R,S
2SC2412KT146 R,S
DTC143EKAT146
DTC144EKAT146

RPI-352Q01R

KRA103RTK
KRA104RTK
KRC102RTK
KRC103RTK
KRC111RTK

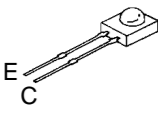
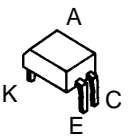

TLP621(GR)

PNA2604M010R

RPI-301

BLOCK DIAGRAM

TV BLOCK DIAGRAM

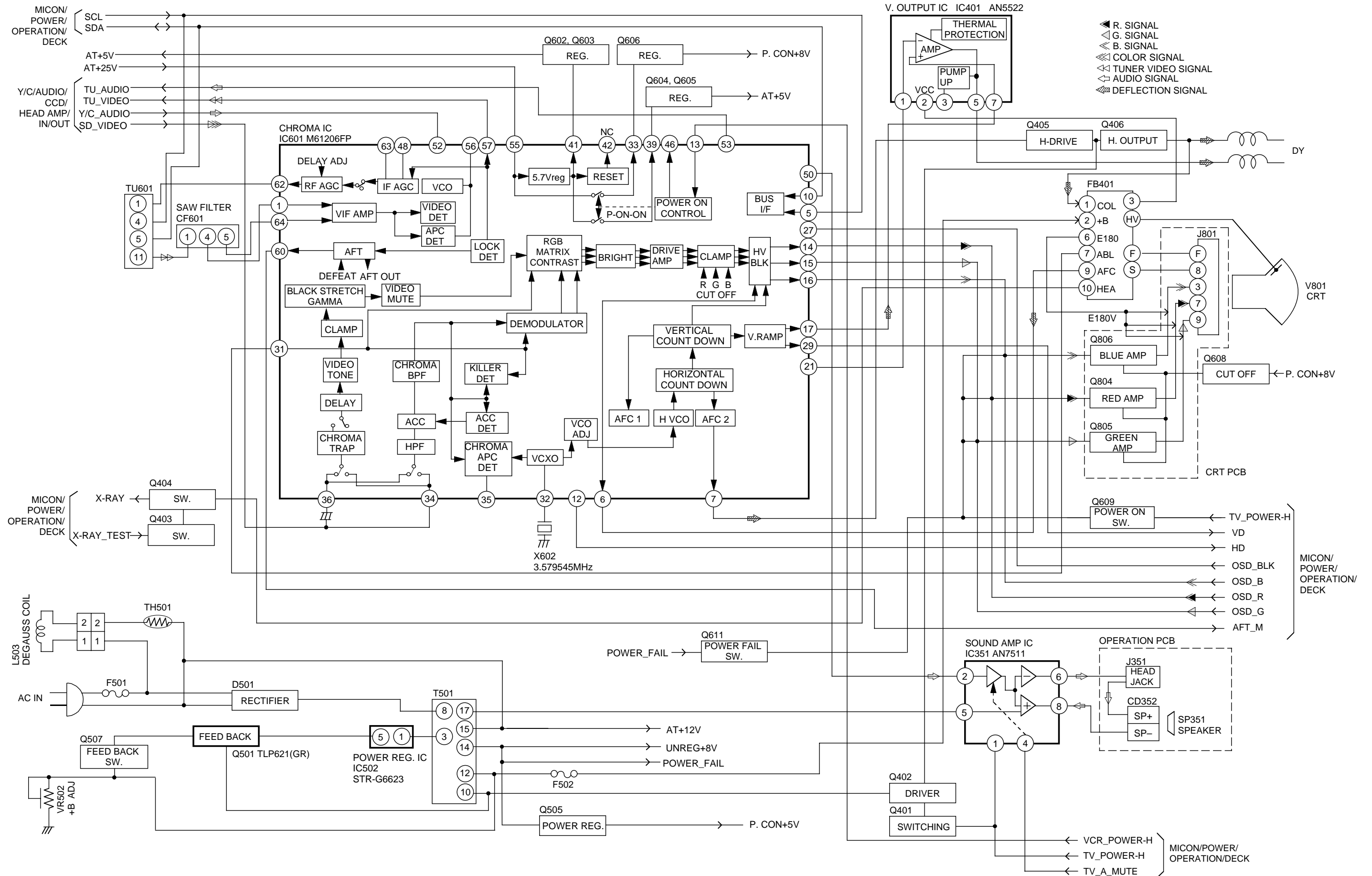

Y/C/AUDIO/CCD/HEAD AMP/IN/OUT BLOCK DIAGRAM

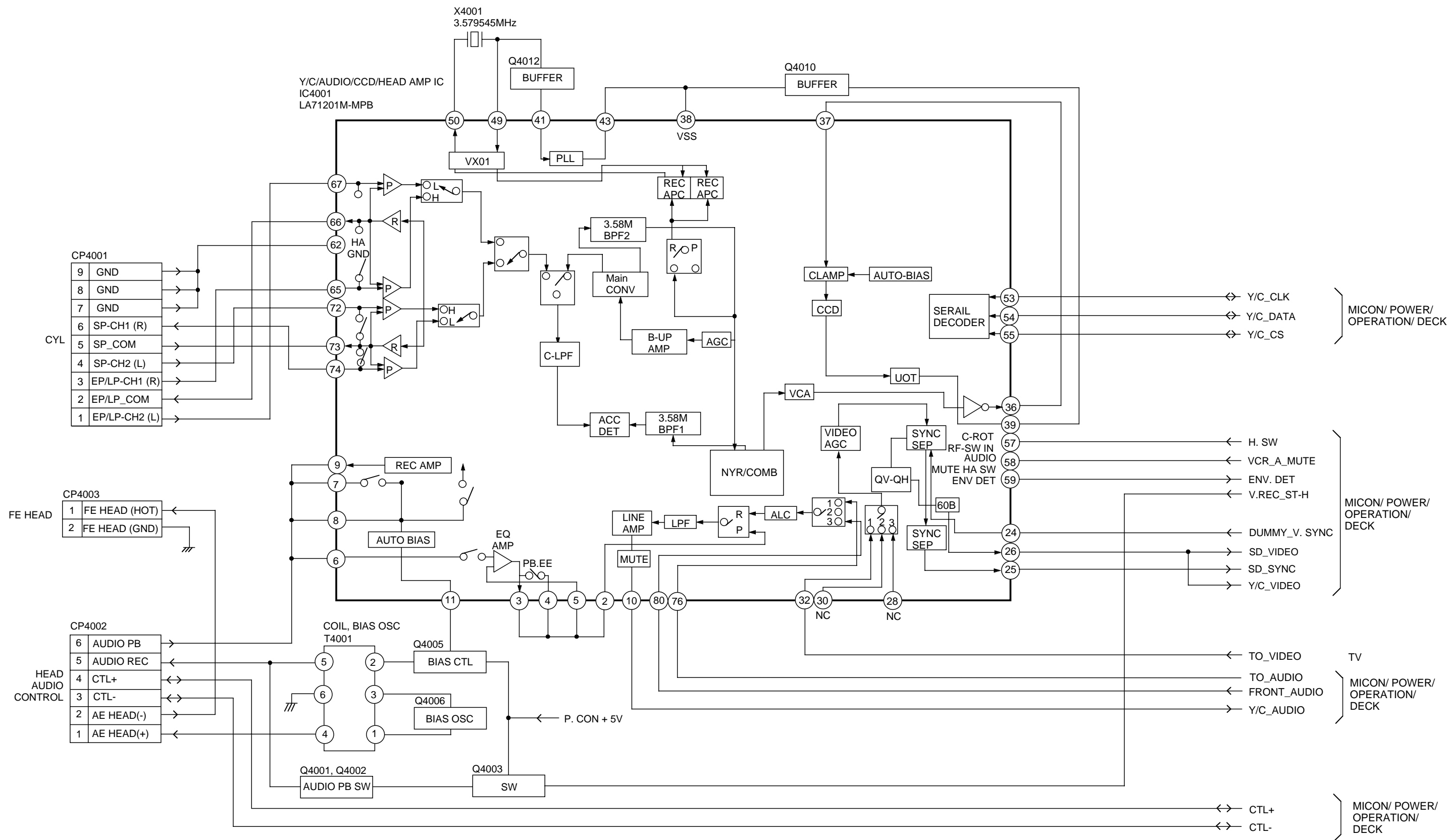

MICON/POWER/OPERATION/DECK BLOCK DIAGRAM

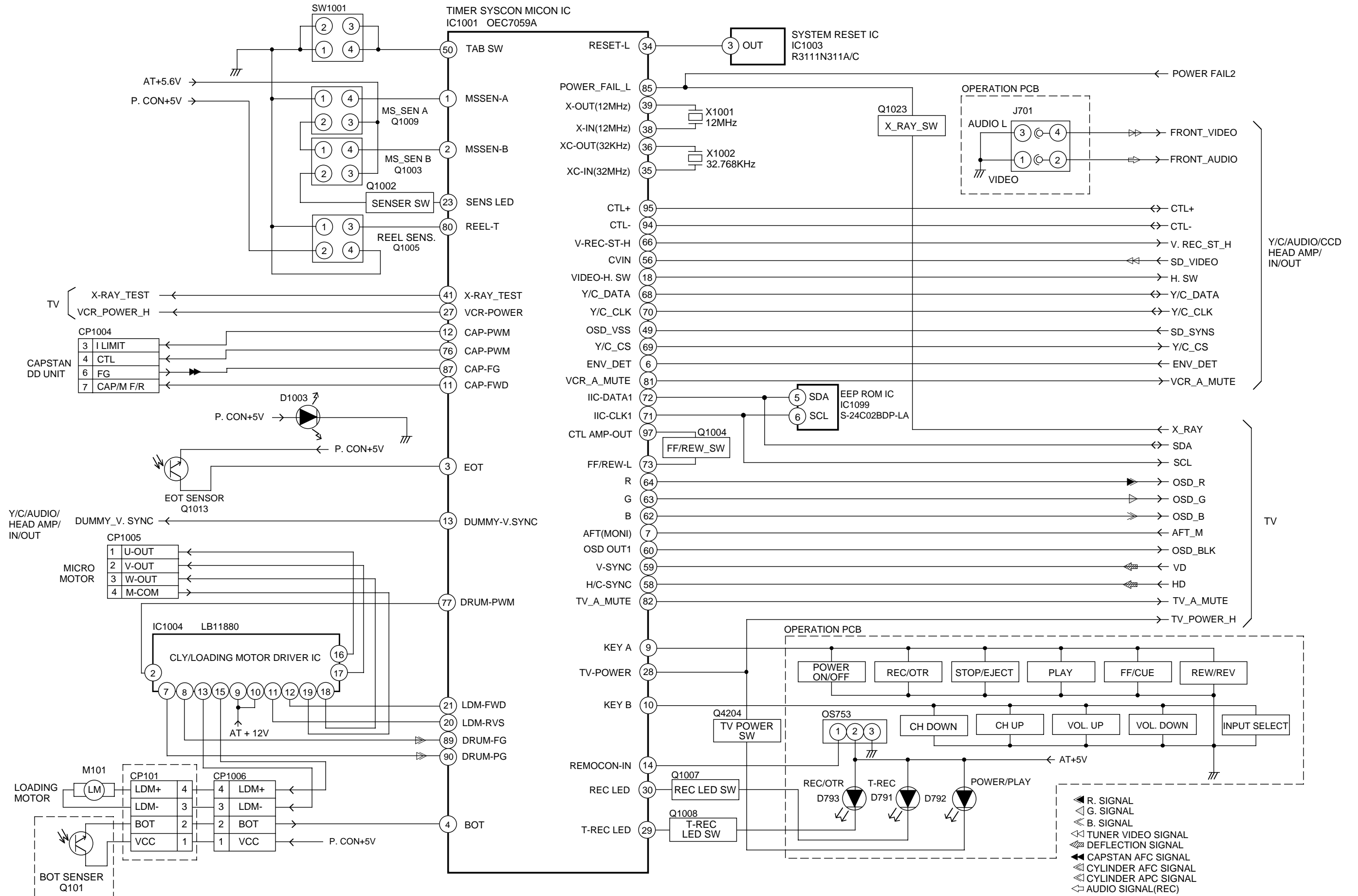

WIRING CONNECTION DIAGRAM

INTERCONNECTION DIAGRAM

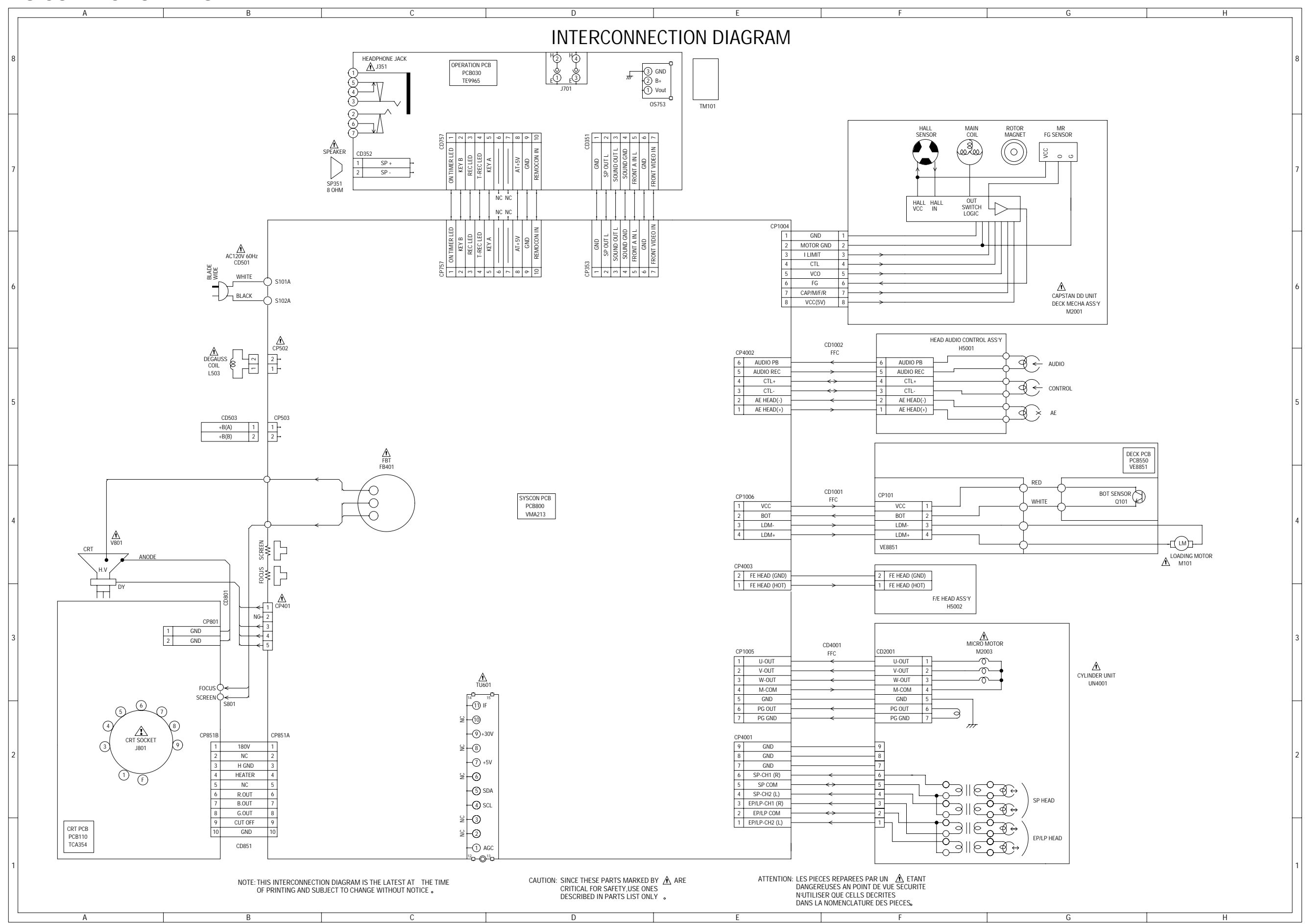

NOTE: THIS INTERCONNECTION DIAGRAM IS THE LATEST AT THE TIME OF PRINTING AND SUBJECT TO CHANGE WITHOUT NOTICE.

CAUTION: SINCE THESE PARTS MARKED BY ARE CRITICAL FOR SAFETY, USE ONES DESCRIBED IN PARTS LIST ONLY.

ATTENTION: LES PIÈCES RÉPARÉES PAR UN ÉTANT DANGEREUSES AU POINT DE VUE SÉCURITÉ, N'UTILISER QUE CELLES DÉCRITES DANS LA NOMENCLATURE DES PIÈCES.

Circuit Diagram
[SYSCON PWB(IN/OUT) CIRCUIT DIAGRAM]

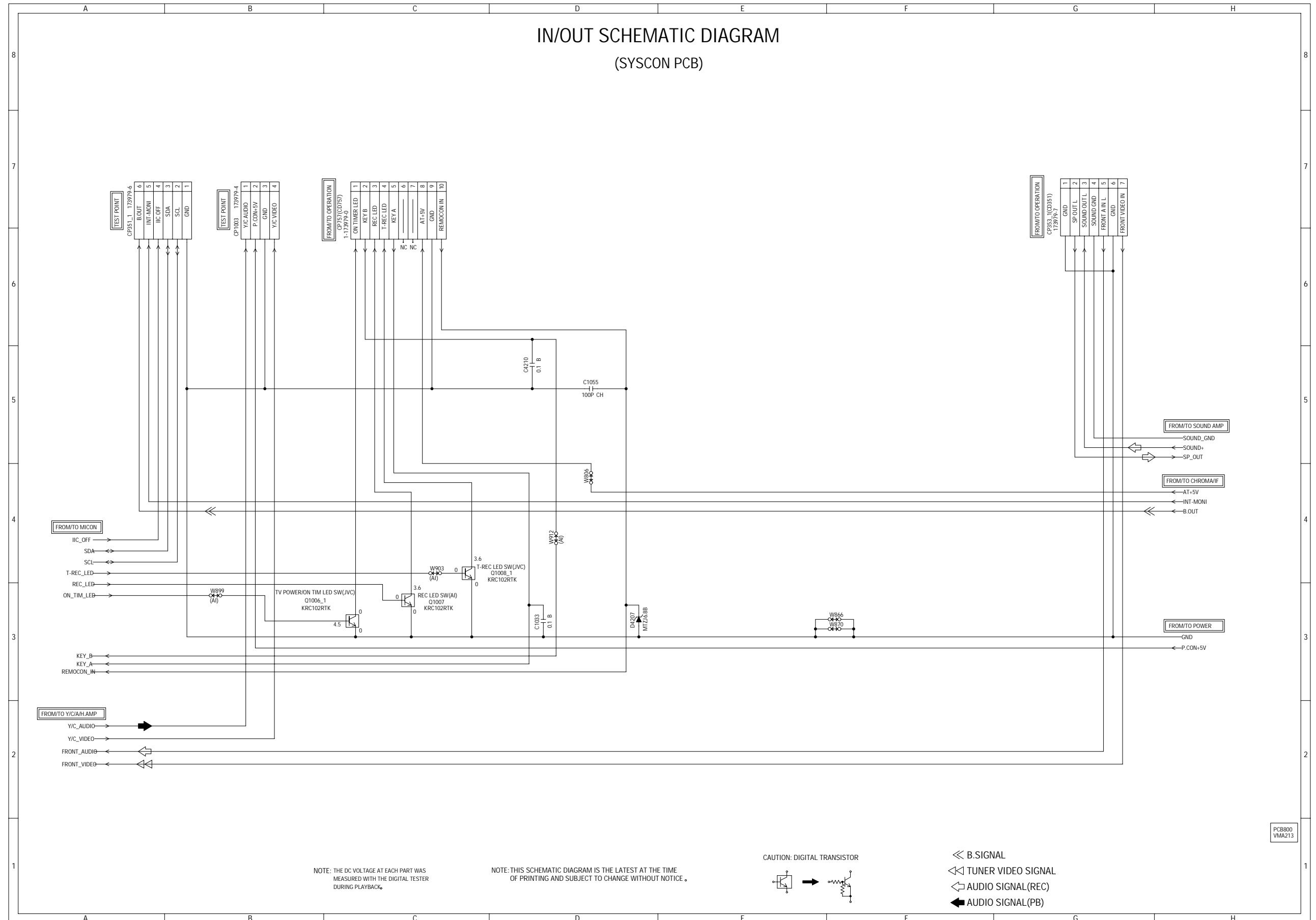

[SYSCON PWB(Y/C/AUDIO/CCD/HEAD AMP) CIRCUIT DIAGRAM]

Y/C/AUDIO/CCD/HEAD AMP SCHEMATIC DIAGRAM
(SYSCON PCB)

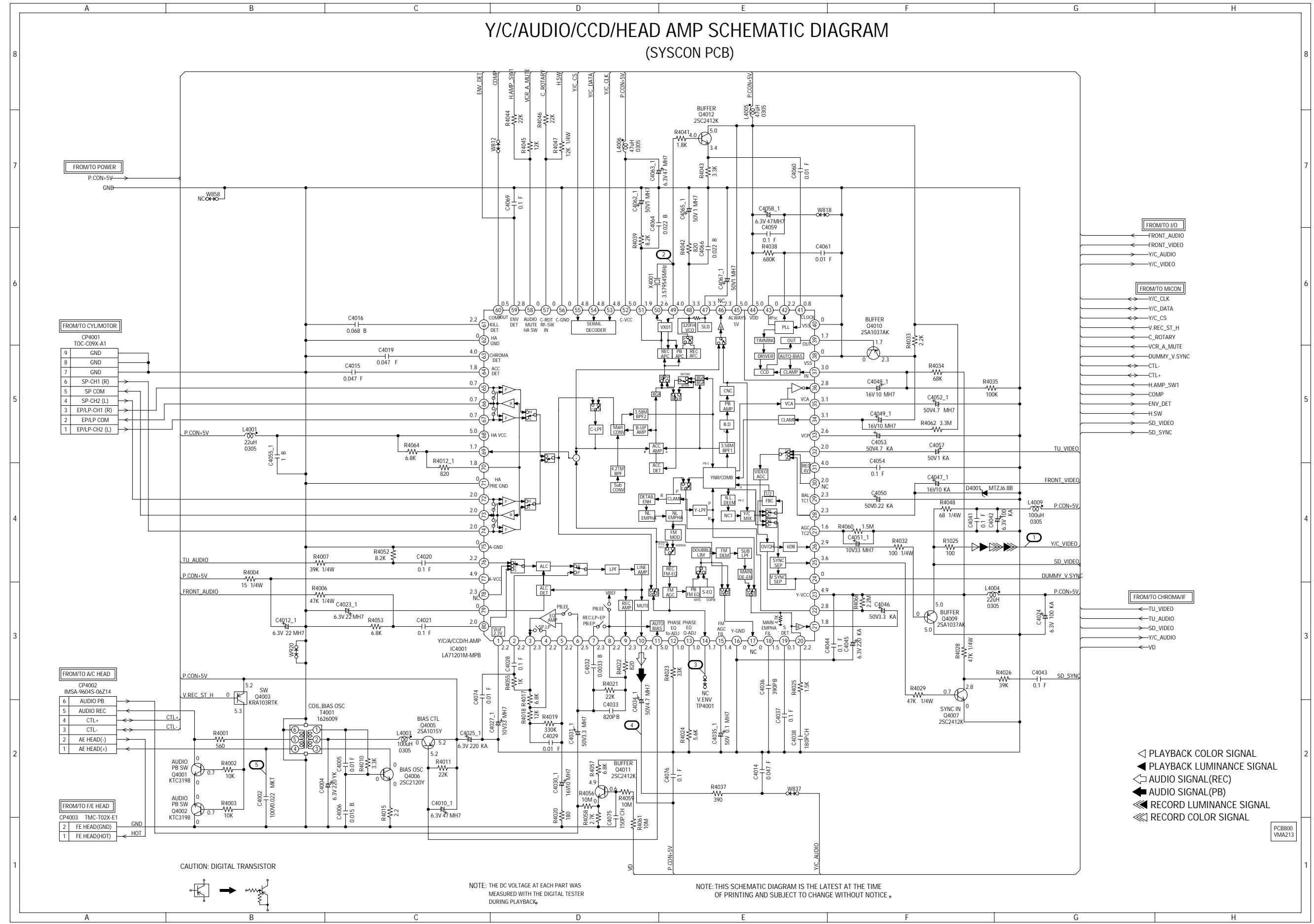

CAUTION: DIGITAL TRANSISTOR

NOTE: THE DC VOLTAGE AT EACH PART WAS MEASURED WITH THE DIGITAL TESTER DURING PLAYBACK.

NOTE: THIS SCHEMATIC DIAGRAM IS THE LATEST AT THE TIME OF PRINTING AND SUBJECT TO CHANGE WITHOUT NOTICE.

- ◁ PLAYBACK COLOR SIGNAL
- ▶ PLAYBACK LUMINANCE SIGNAL
- ◁ AUDIO SIGNAL(REC)
- ▶ AUDIO SIGNAL(PB)
- ◁ RECORD LUMINANCE SIGNAL
- ▶ RECORD COLOR SIGNAL

PCB800
VMA213

[SYSCON PWB(MICON) CIRCUIT DIAGRAM]

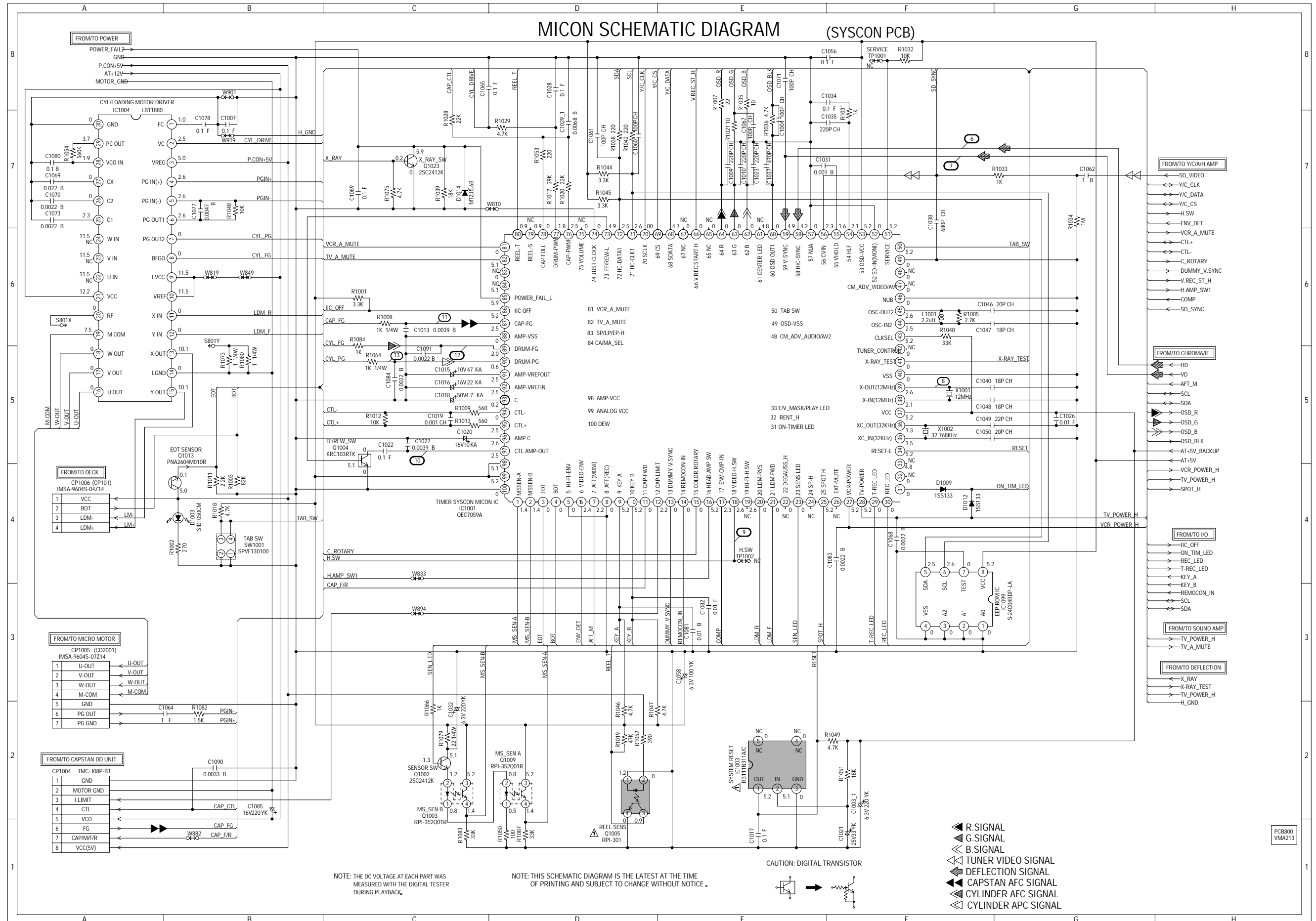

[SYSCON PWB(CHROMA/IF) CIRCUIT DIAGRAM]

CHROMA/IF SCHEMATIC DIAGRAM (SYSCON PCB)

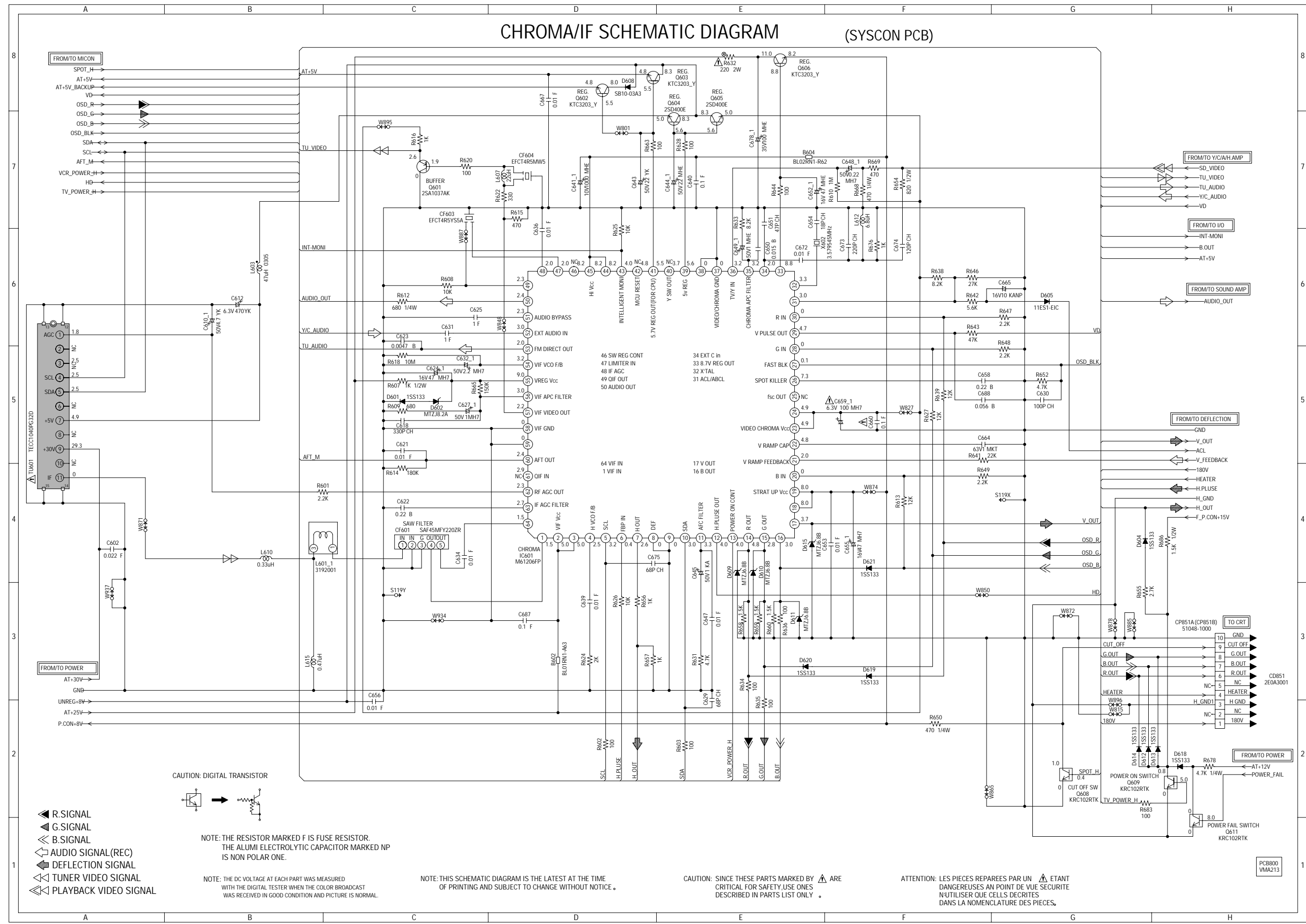

CAUTION: DIGITAL TRANSISTOR

NOTE: THE RESISTOR MARKED F IS FUSE RESISTOR.
THE ALUMI ELECTROLYTIC CAPACITOR MARKED NP IS NON POLAR ONE.

NOTE: THE DC VOLTAGE AT EACH PART WAS MEASURED WITH THE DIGITAL TESTER WHEN THE COLOR BROADCAST WAS RECEIVED IN GOOD CONDITION AND PICTURE IS NORMAL.

NOTE: THIS SCHEMATIC DIAGRAM IS THE LATEST AT THE TIME OF PRINTING AND SUBJECT TO CHANGE WITHOUT NOTICE.

CAUTION: SINCE THESE PARTS MARKED BY \triangle ARE CRITICAL FOR SAFETY, USE ONES DESCRIBED IN PARTS LIST ONLY.

ATTENTION: LES PIÈCES REPARÉES PAR UN \triangle ÉTANT DANGEREUSES AN POINT DE VUE SECURITE N'UTILISER QUE CELLS DECRITES DANS LA NOMENCLATURE DES PIÈCES.

[SYSCON PWB(SOUND AMP) CIRCUIT DIAGRAM]

SOUND AMP SCHEMATIC DIAGRAM
(SYSCON PCB)

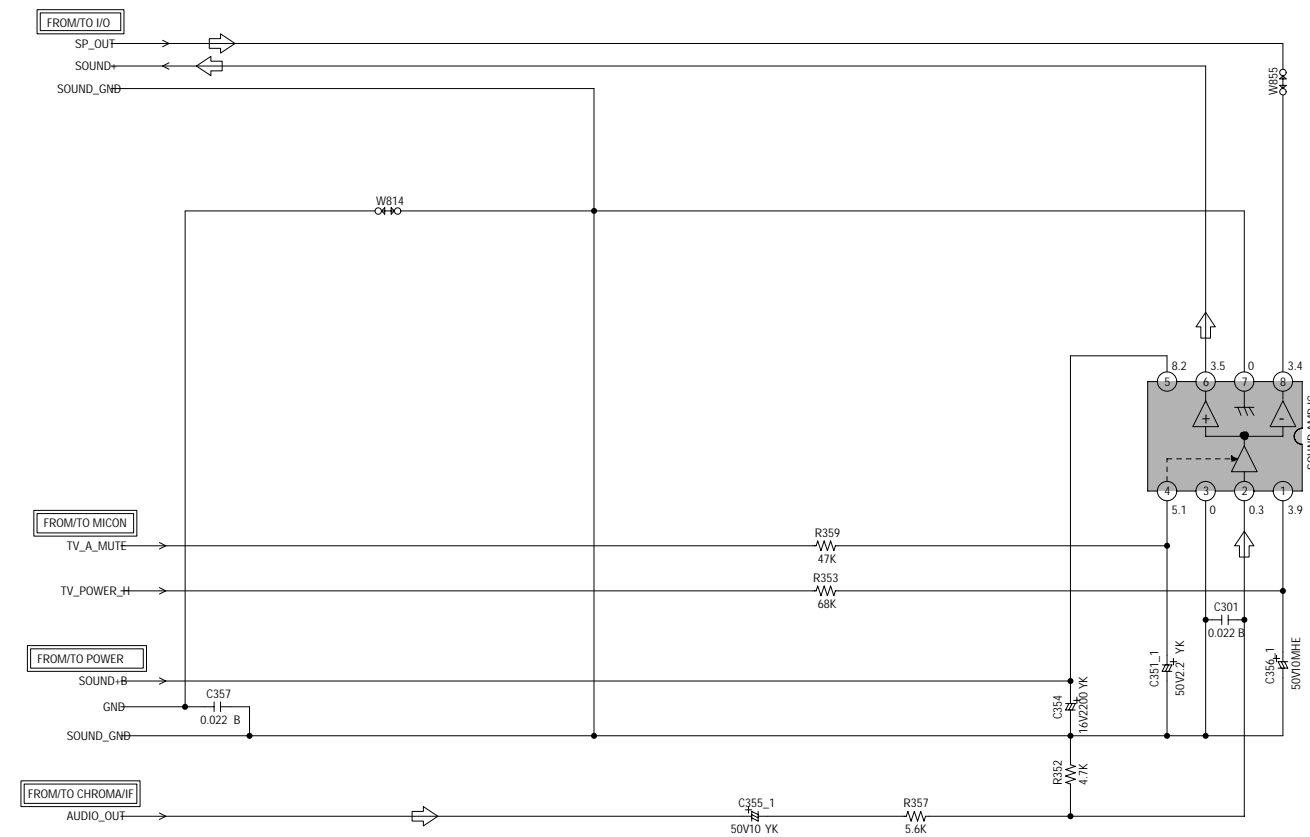

⇐ AUDIO SIGNAL(REC)

NOTE: THE DC VOLTAGE AT EACH PART WAS MEASURED WITH THE DIGITAL TESTER WHEN THE COLOR BROADCAST WAS RECEIVED IN GOOD CONDITION AND PICTURE IS NORMAL.

NOTE: THIS SCHEMATIC DIAGRAM IS THE LATEST AT THE TIME OF PRINTING AND SUBJECT TO CHANGE WITHOUT NOTICE.

CAUTION: SINCE THESE PARTS MARKED BY ⚠ ARE CRITICAL FOR SAFETY, USE ONES DESCRIBED IN PARTS LIST ONLY.

ATTENTION: LES PIÈCES RÉPARÉES PAR UN ⚠ ÉTANT DANGEREUSES AN POINT DE VUE SECURITE N'UTILISER QUE CELLS DÉCRITES DANS LA NOMENCLATURE DES PIÈCES.

PCB800
VMA213

[SYSCON PWB(POWER) CIRCUIT DIAGRAM]

POWER SCHEMATIC DIAGRAM
(SYSCON PCB)

CAUTION: FOR CONTINUED PROTECTION AGAINST FIRE HAZARD,
REPLACE ONLY WITH THE SAME TYPE FUSE 5A 125V (F501).
ATTENTION: POUR UNE PROTECTION CONTINUE LES RISQUES D'INCE
N'UTILISER QUE DES FUSIBLE DE MEME TYPE 5A 125V (F501).

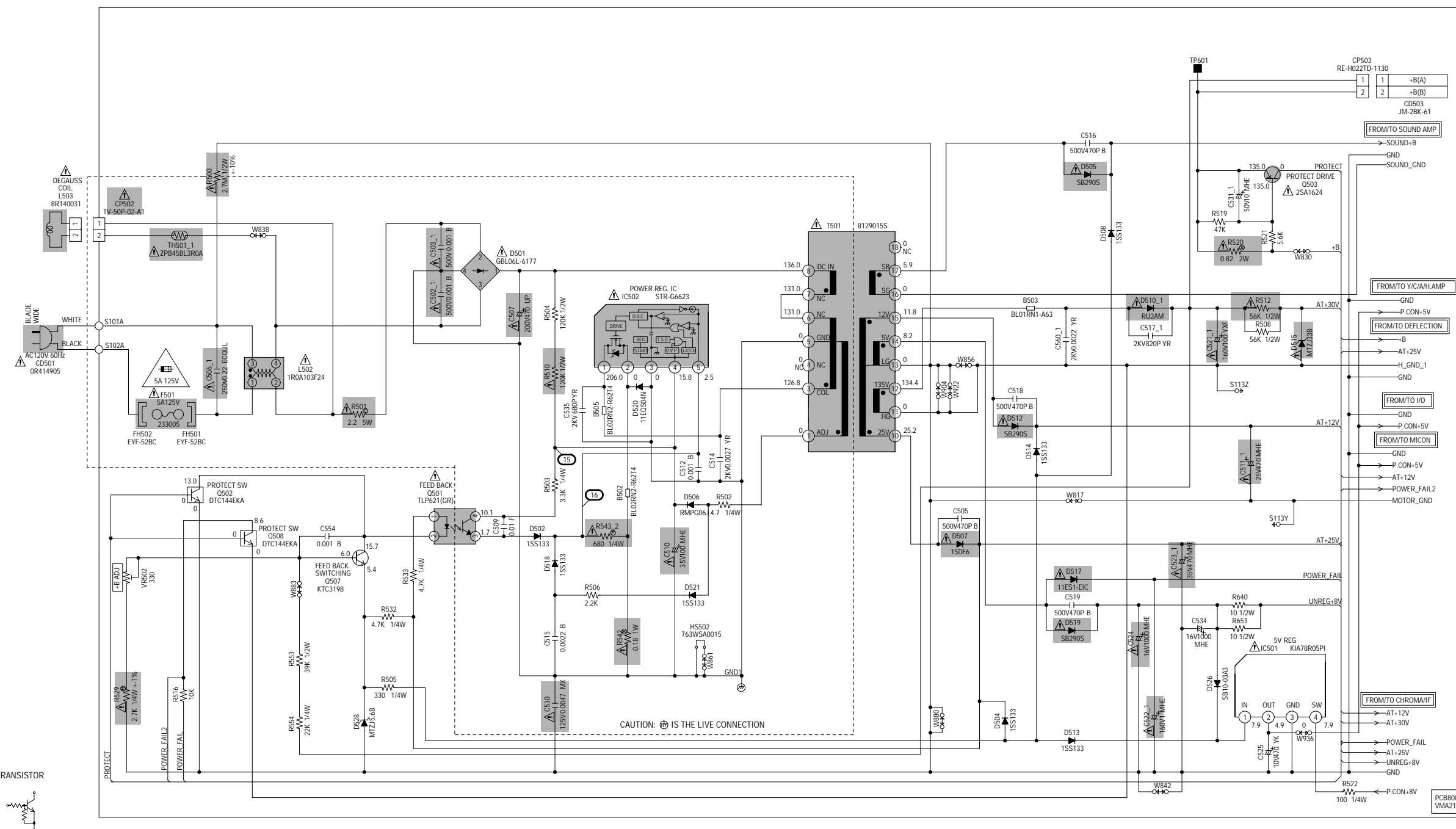

CAUTION: DIGITAL TRANSISTOR

CAUTION: ⚡ IS THE LIVE CONNECTION

NOTE: THE RESISTOR MARKED F IS FUSE RESISTOR.
THE ALUMI ELECTROLYTIC CAPACITOR MARKED NP
IS NON POLAR ONE.

NOTE: THE DC VOLTAGE AT EACH PART WAS MEASURED
WITH THE DIGITAL TESTER WHEN THE COLOR BROADCAST
WAS RECEIVED IN GOOD CONDITION AND PICTURE IS NORMAL.

NOTE: THIS SCHEMATIC DIAGRAM IS THE LATEST AT THE TIME
OF PRINTING AND SUBJECT TO CHANGE WITHOUT NOTICE.

CAUTION: SINCE THESE PARTS MARKED BY ⚡ ARE
CRITICAL FOR SAFETY USE ONES
DESCRIBED IN PARTS LIST ONLY.

ATTENTION: LES PIECES REPARÉES PAR UN ⚡ ETANT
DANGEREUSES AN POINT DE VUE SECURITE
N'UTILISER QUE CELLS DECRITES
DANS LA NOMENCLATURE DES PIECES.

[SYSCON PWB(DEFLECTION) CIRCUIT DIAGRAM]

DEFLECTION SCHEMATIC DIAGRAM
(SYSCON PCB)

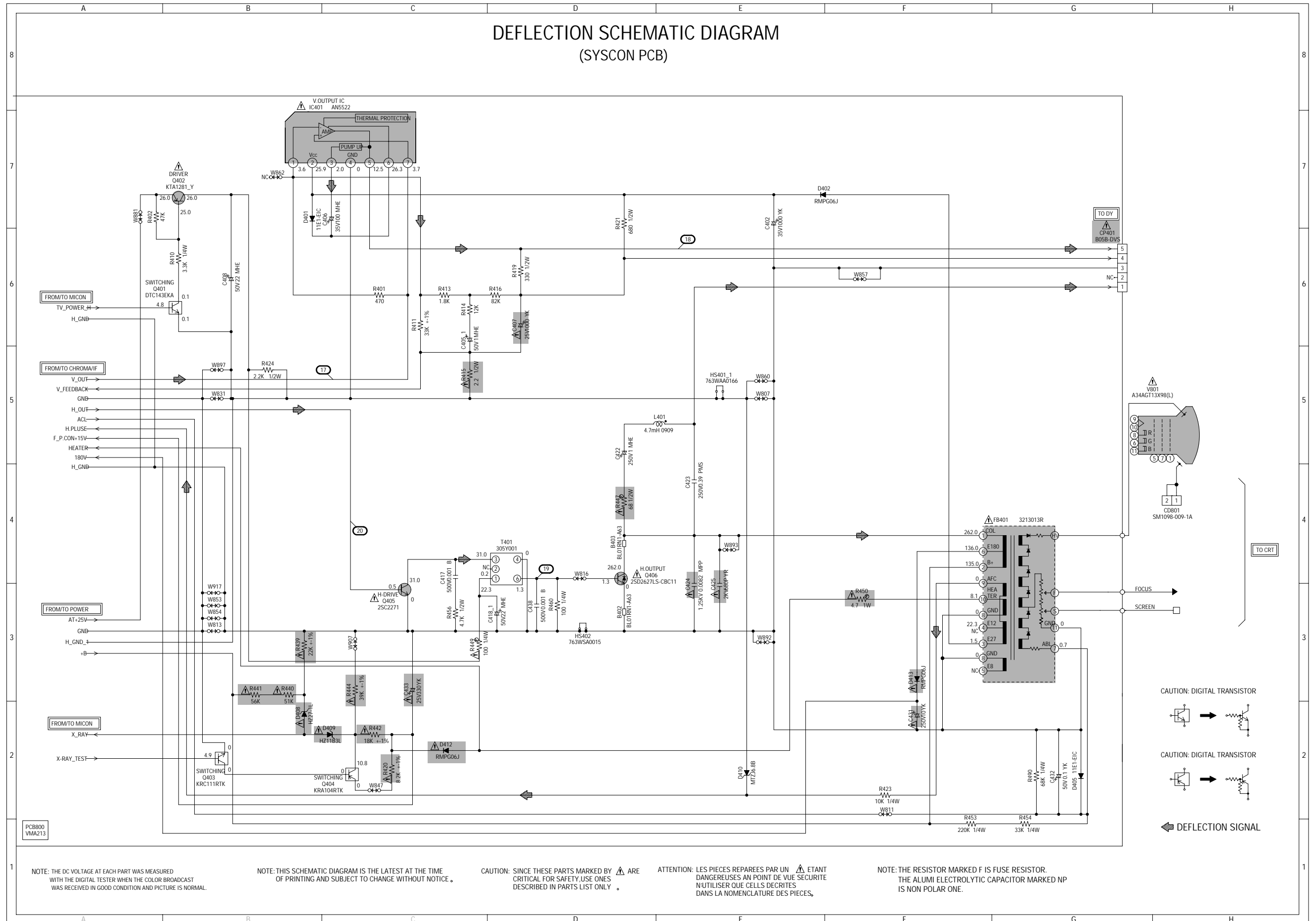

NOTE: THE DC VOLTAGE AT EACH PART WAS MEASURED WITH THE DIGITAL TESTER WHEN THE COLOR BROADCAST WAS RECEIVED IN GOOD CONDITION AND PICTURE IS NORMAL.

NOTE: THIS SCHEMATIC DIAGRAM IS THE LATEST AT THE TIME OF PRINTING AND SUBJECT TO CHANGE WITHOUT NOTICE.

CAUTION: SINCE THESE PARTS MARKED BY ARE CRITICAL FOR SAFETY USE ONES DESCRIBED IN PARTS LIST ONLY.

ATTENTION: LES PIÈCES RÉPARÉES PAR UN ÉTANT DANGEREUSES AN POINT DE VUE SÉCURITÉ N'UTILISER QUE CELLES DÉCRITES DANS LA NOMENCLATURE DES PIÈCES.

NOTE: THE RESISTOR MARKED F IS FUSE RESISTOR. THE ALUMI ELECTROLYTIC CAPACITOR MARKED NP IS NON POLAR ONE.

[CRT PWB CIRCUIT DIAGRAM]

CRT SCHEMATIC DIAGRAM
(CRT PCB)

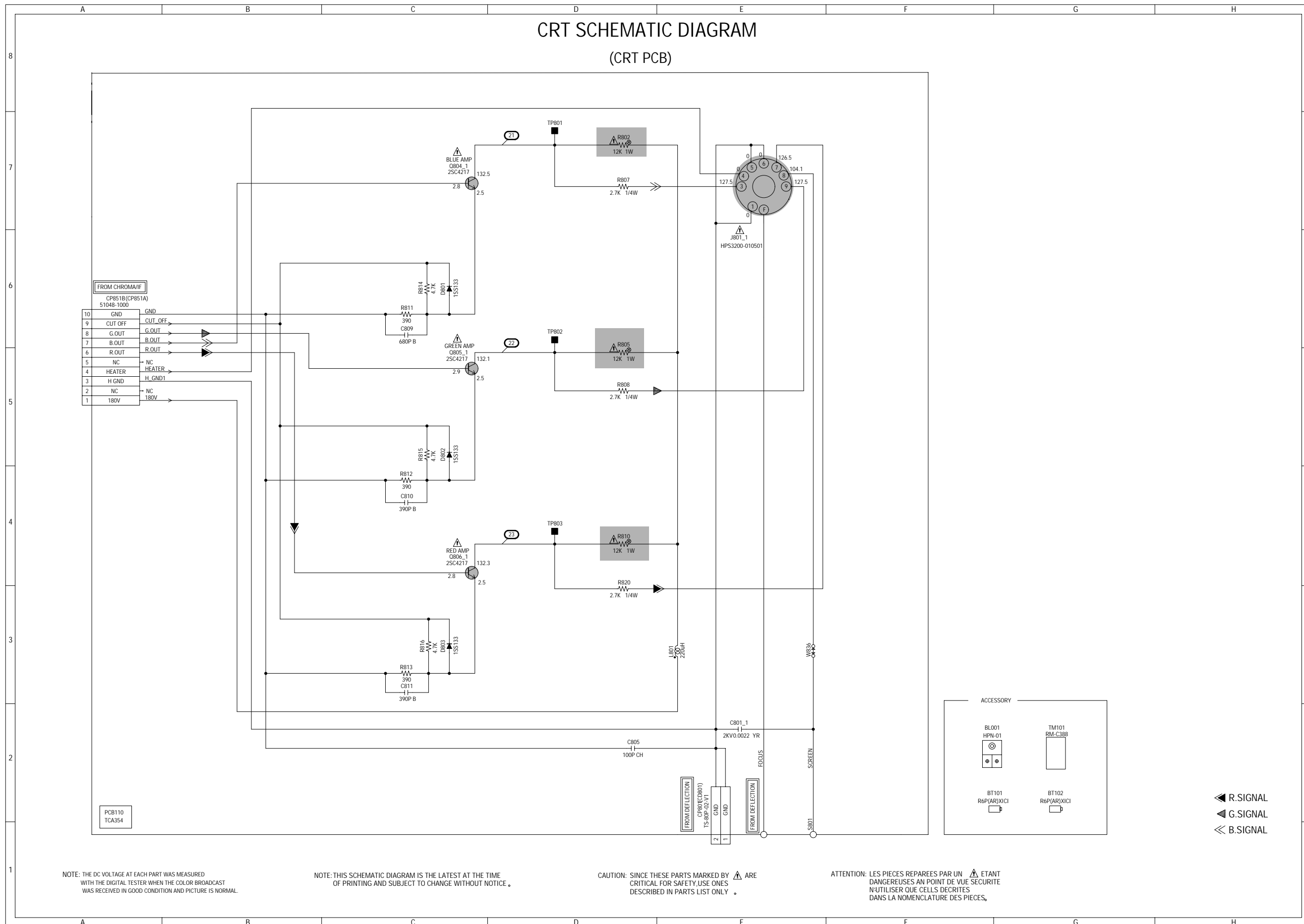

FROM CHROMA/IF	
CP851B(CP851A) 51048-1000	
10	GND
9	CUT OFF
8	G. OUT
7	B. OUT
6	R. OUT
5	NC
4	HEATER
3	H. GND1
2	NC
1	180V

PCB110
TCA354

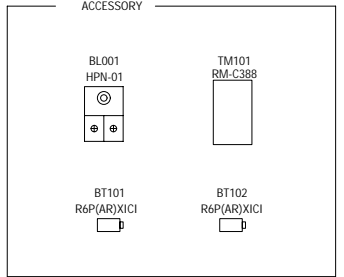

◀ R.SIGNAL
◀ G.SIGNAL
◀ B.SIGNAL

NOTE: THE DC VOLTAGE AT EACH PART WAS MEASURED WITH THE DIGITAL TESTER WHEN THE COLOR BROADCAST WAS RECEIVED IN GOOD CONDITION AND PICTURE IS NORMAL.

NOTE: THIS SCHEMATIC DIAGRAM IS THE LATEST AT THE TIME OF PRINTING AND SUBJECT TO CHANGE WITHOUT NOTICE.

CAUTION: SINCE THESE PARTS MARKED BY ⚠ ARE CRITICAL FOR SAFETY, USE ONES DESCRIBED IN PARTS LIST ONLY.

ATTENTION: LES PIÈCES REPARÉES PAR UN ⚠ ÉTANT DANGEREUSES AU POINT DE VUE SÉCURITÉ N'UTILISER QUE CELLES DÉCRITES DANS LA NOMENCLATURE DES PIÈCES.

[DECK PWB CIRCUIT DIAGRAM]

DECK SCHEMATIC DIAGRAM
(DECK PCB)

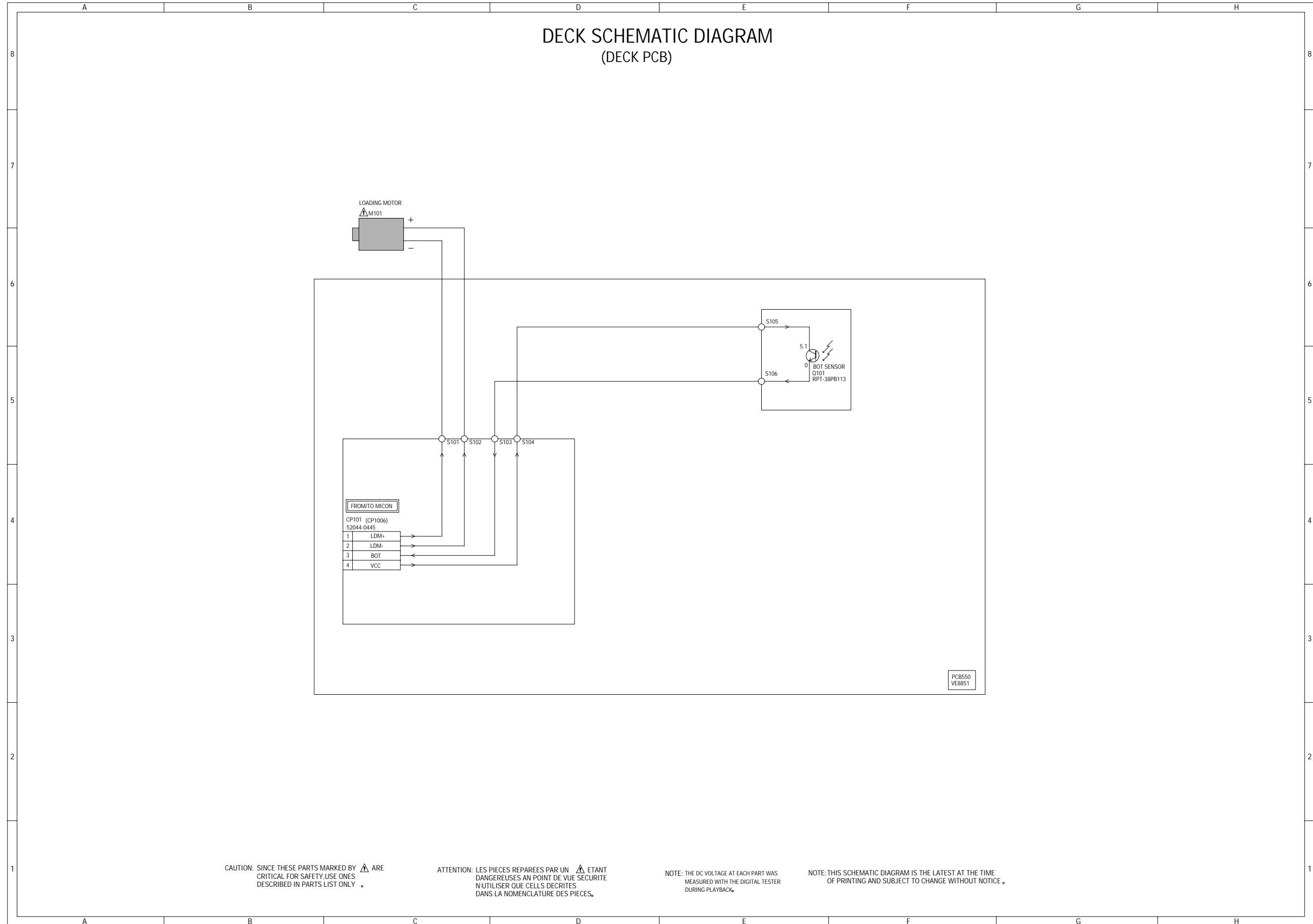

CAUTION: SINCE THESE PARTS MARKED BY ARE CRITICAL FOR SAFETY, USE ONES DESCRIBED IN PARTS LIST ONLY .

ATTENTION: LES PIECES REPARÉES PAR UN ÉTANT DANGEREUSES AN POINT DE VUE SECURITE N'UTILISER QUE CELLS DECRITES DANS LA NOMENCLATURE DES PIECES.

NOTE: THE DC VOLTAGE AT EACH PART WAS MEASURED WITH THE DIGITAL TESTER DURING PLAYBACK.

NOTE: THIS SCHEMATIC DIAGRAM IS THE LATEST AT THE TIME OF PRINTING AND SUBJECT TO CHANGE WITHOUT NOTICE .

PATTERN DIAGRAMS
[OPERATION PWB PATTERN]

INSERTED PARTS

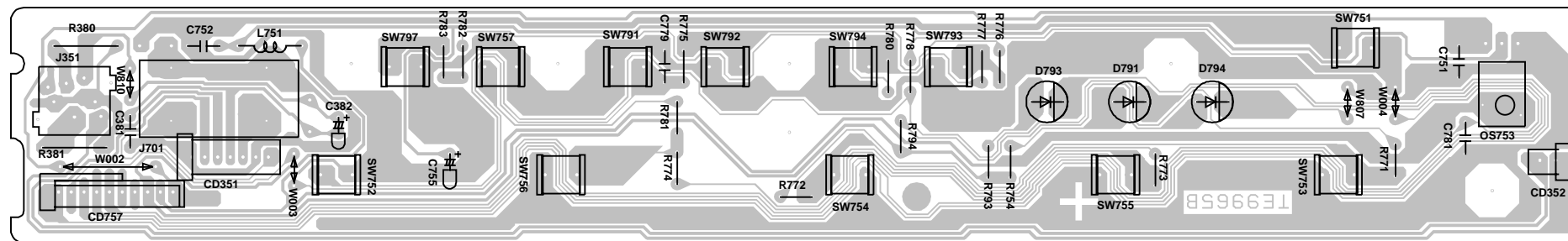

CHIP MOUNTED PARTS

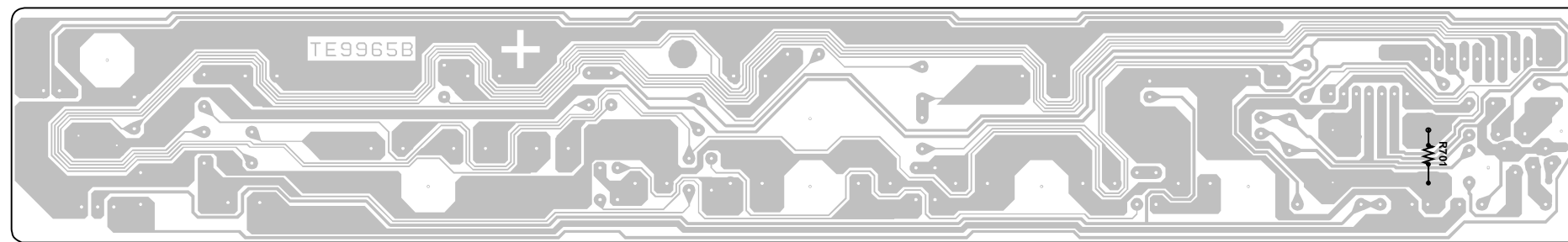

[DECK PWB PATTERN]

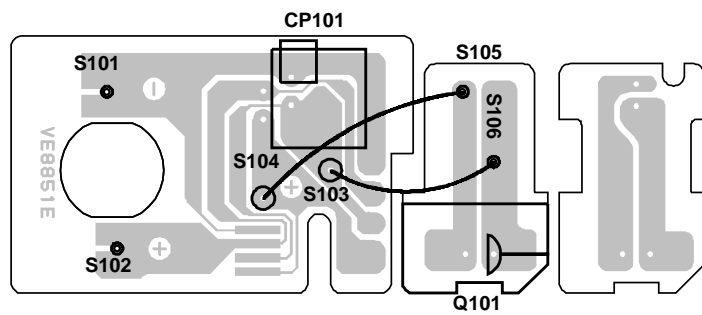

[SYSCON/CRT PWB PATTERN(CHIP MOUNTED PARTS)]

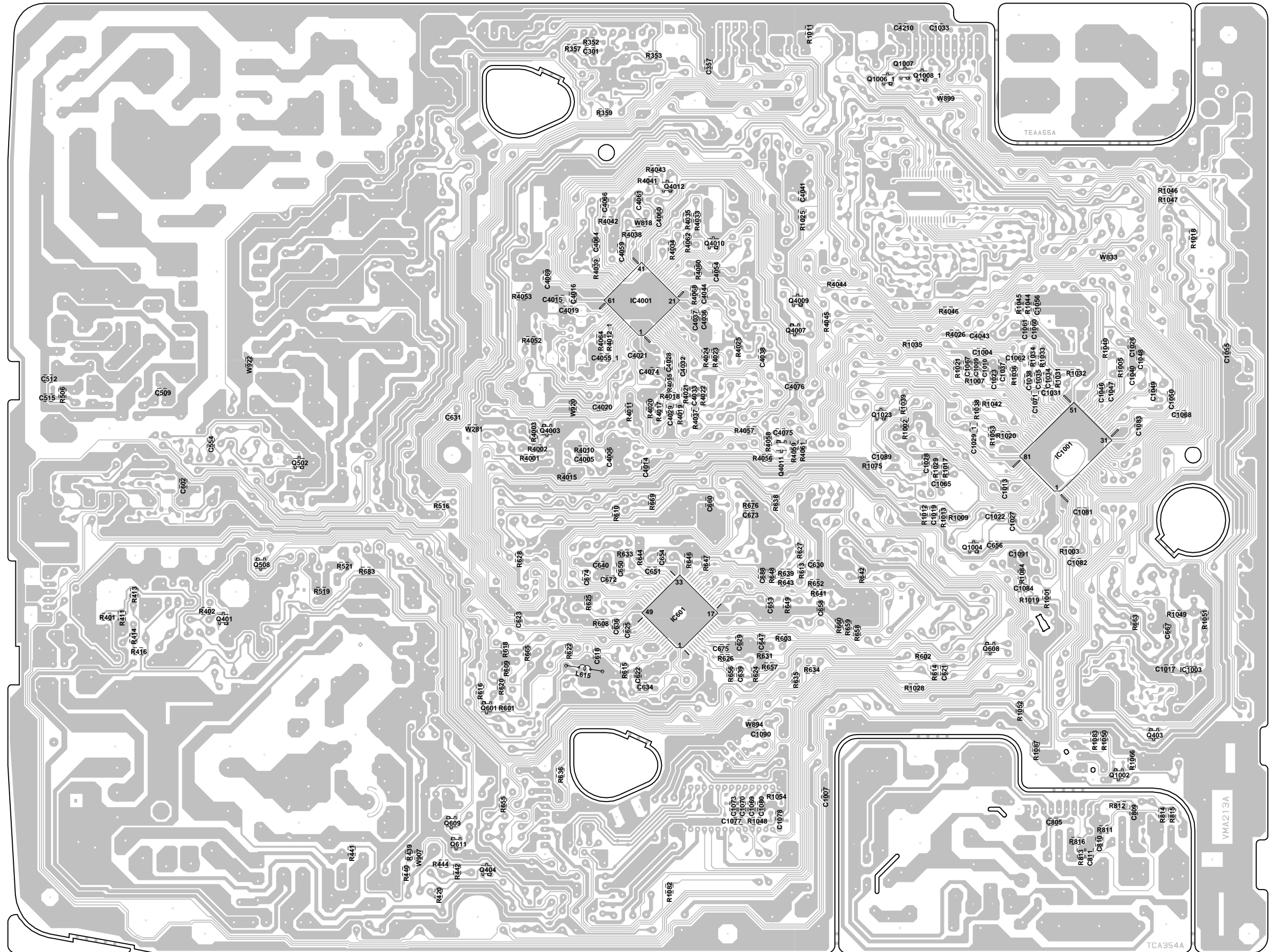

WAVEFORMS

Y/C/AUDIO/CCD/HEAD AMP

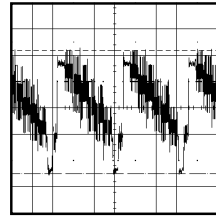

① PB
0.5V 20 s/div

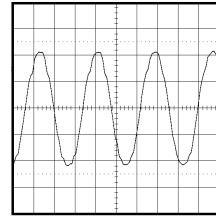

② POWER ON
100mV 0.1 s/div

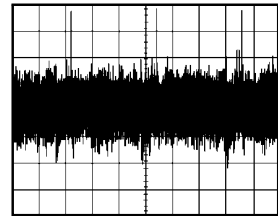

③ PB
10mV 20us/div

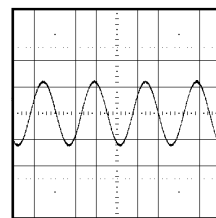

④ PB
0.5V 1ms/div

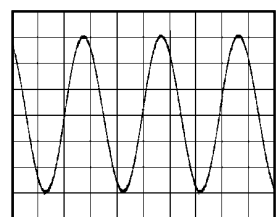

⑤ REC
10.0V 5us/div

MICON

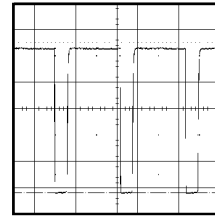

⑥ POWER ON
1.0V 20 s/div

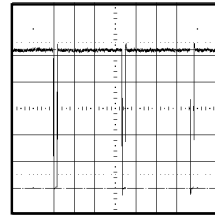

⑦ POWER ON
0.5V 10ms/div

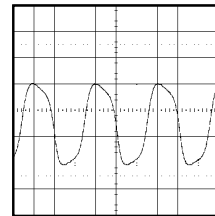

⑧ POWER ON
1.0V 10 s/div

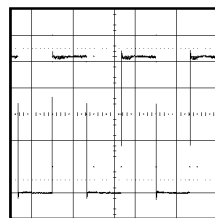

⑨ PB
1.0V 10ms/div

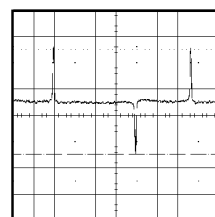

⑩ PB
1.0V 5ms/div

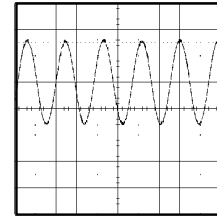

⑪ PB
0.5V 0.5ms/div

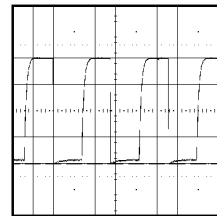

⑫ PB
1.0V 0.5ms/div

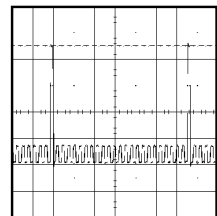

⑬ PB
1.0V 5ms/div

POWER

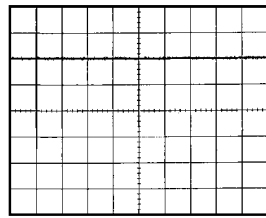

⑮ 5.0V 20ms/div

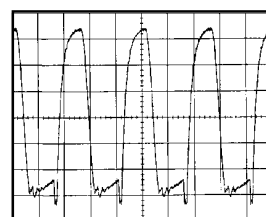

⑯ 500mV 5 s/div

DEFLECTION

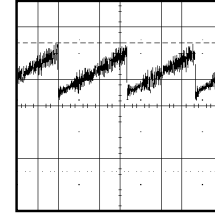

⑰ 0.5V 5ms/div

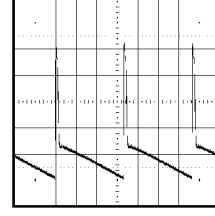

⑱ 10.0V 5ms/div

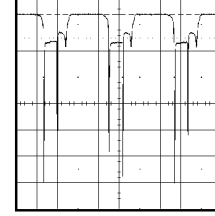

⑲ 2.0V 20 s/div

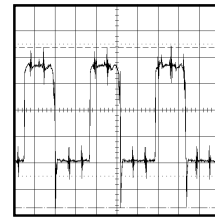

⑳ 200mV 20 s/div

CRT

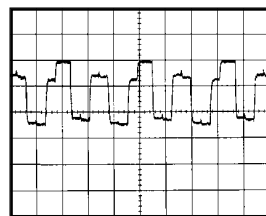

㉑ 50.0V 20 s/div

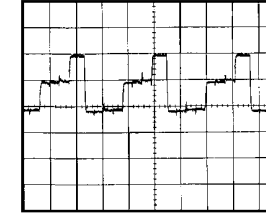

㉒ 50.0V 20 s/div

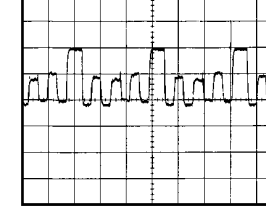

㉓ 50.0V 20 s/div

NOTE: The following waveforms were measured at the point of the corresponding balloon number in the schematic diagram.

NOTE: The following waveforms were measured at the point of the corresponding balloon number in the schematic diagram.